

# ELEVATOR BOLTS

Same Day Shipping Available

## STANDARD ELEVATOR BOLT

- Standard #1 Norway
- Carbon
  - 302 Stainless Steel
  - Zinc Plated



STANDARD ELEVATOR BOLT			
SIZE, INCHES	WEIGHT / 100 PCS., LBS.	CASE QTY	KEG BULK QTY
1/4 x 3/4	2.94	1200	2000
1/4 x 1 *	3.24	1200	1700
1/4 x 1-1/4 *	3.43	1200	1500
1/4 x 1-1/2 *	3.73	1200	1300
1/4 x 1-3/4	3.98	1200	1200
1/4 x 2	4.29	1200	1000
1/4 x 2-1/4	4.88	600	900
1/4 x 2-1/2	4.92	600	800
5/16 x 3/4	4.76	1200	1200
5/16 x 1 *	5.05	1200	1000
5/16 x 1-1/4 *	5.55	1200	900
5/16 x 1-1/2 *	6.38	600	800
5/16 x 1-3/4 *	6.50	600	700
5/16 x 2 *	7.12	600	600
5/16 x 2-1/4	7.43	600	550
5/16 x 2-1/2	7.78	600	500
3/8 x 1-1/4	6.54	600	750
3/8 x 1-1/2	7.10	600	700
3/8 x 1-3/4	7.66	600	600
3/8 x 2 *	8.31	600	500
3/8 x 2-1/4	9.35	600	450
3/8 x 2-1/2	9.83	600	400
3/8 x 3	10.79	600	300

## SABRE-TOOTH® ELEVATOR BOLT

- Sabre-Tooth®
- Carbon
  - 302 Stainless Steel
  - Zinc Plated

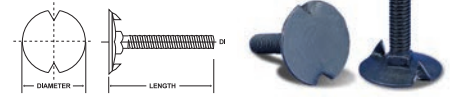

SABRE-TOOTH ELEVATOR BOLT			
SIZE, INCHES	WEIGHT / 100 PCS., LBS.	CASE QTY	KEG BULK QTY
1/4 x 3/4	2.94	1200	2000
1/4 x 1 *	3.24	1200	1700
1/4 x 1-1/4 *	3.43	1200	1500
1/4 x 1-1/2 *	3.73	1200	1300
1/4 x 1-3/4	3.98	1200	1200
1/4 x 2 *	4.29	1200	1000
1/4 x 2-1/4	4.88	600	900
1/4 x 2-1/2	4.92	600	800
5/16 x 3/4	4.76	1200	1200
5/16 x 1 *	5.05	1200	1000
5/16 x 1-1/4 *	5.55	1200	900
5/16 x 1-1/2 *	6.38	600	800
5/16 x 1-3/4 *	6.50	600	700
5/16 x 2 *	7.12	600	600
5/16 x 2-1/4	7.43	600	550
5/16 x 2-1/2	7.78	600	500
3/8 x 1-1/4	6.54	600	750
3/8 x 1-1/2	7.10	600	700
3/8 x 1-3/4	7.66	600	600
3/8 x 2 *	8.31	600	500
3/8 x 2-1/4	9.35	600	450
3/8 x 2-1/2	9.83	600	400
3/8 x 3	10.79	600	300

## RELIANCE ELEVATOR BOLT

- #3 Slotted Head
- Carbon Steel
  - Zinc Plated

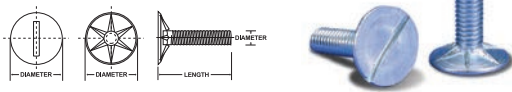

RELIANCE ELEVATOR BOLT			
SIZE, INCHES	WEIGHT / 100 PCS., LBS.	CASE QTY	KEG BULK QTY
1/4 x 3/4	2.7	1200	2400
1/4 x 1	1.9	1800	2500
1/4 x 1-1/4	3.0	1200	1800
1/4 x 1-1/2	3.5	1200	1800
5/16 x 1-1/4	4.9	1200	1200

## SABRE-TOOTH® BOLT (POINTED)

- Sabre-Tooth®
- Carbon Steel

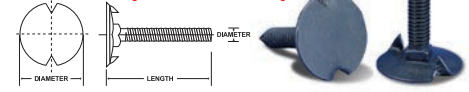

SABRE-TOOTH ELEVATOR BOLT			
SIZE, INCHES	WEIGHT / 100 PCS., LBS.	CASE QTY	KEG BULK QTY
1/4 x 1-1/4	2.52	1800	2100
1/4 x 1-1/2	2.78	1300	1800
5/16 X 1-1/4	4.60	900	1200
5/16 X 1-1/2	4.15	1000	1500

## HEX HEAD BOLT

- Zinc Plated • Grade 5
- Used with Chain Attachments

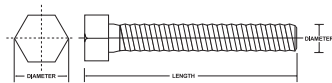

HEX-HEAD BOLT			
SIZE, INCHES	WEIGHT / 100 PCS., LBS.	CASE QTY	KEG BULK QTY
1/2 X 1	8.50	1200	1700
1/2 x 1-1/4	9.45	1200	1500
1/2 x 1-1/2	10.70	1200	1300
3/8 x 1	4.15	1200	1700
3/8 x 1-1/4	4.80	1200	1500
3/8 x 1-1/2	5.65	1200	1300

Maxi-Lift continually applies metallography tests to our fasteners to ensure the finest quality parts are upheld.

Maxi-Lift exceeds all industry standards for grade 2 elevator bolts.

# WASHERS, NUTS & SPACERS

Call 1-800-527-0657, Visit [MAXILIFT.COM](http://MAXILIFT.COM) for More Info

## NUTS

STANDARD HEX		SIZE, INCHES (ID)	PKG. QTY., PCS.	PKG. WEIGHT, LBS.
		1/4-20	100	0.7
		5/16-18	100	1.1
		3/8-16	100	1.6
	<i>Available in zinc and stainless.</i>	1/2	100	3.8

  

STANDARD FLANGE SERRATED LOCK		SIZE, INCHES (ID)	PKG. QTY., PCS.	PKG. WEIGHT, LBS.
		1/4-20	100	0.9
		5/16-18	100	1.2
		3/8-16	100	1.8
	<i>Available in zinc and stainless.</i>			

LARGE FLANGE SERRATED LOCK		SIZE, INCHES (ID)	PKG. QTY., PCS.	PKG. WEIGHT, LBS.
		1/4-20	100	1.2
		5/16-18	100	2.3
		3/8-16	100	2.8
	<i>Available in zinc.</i>			

NYLON INSERT LOCK		SIZE, INCHES (ID)	PKG. QTY., PCS.	PKG. WEIGHT, LBS.
		1/4-20	100	0.8
		5/16-18	100	1.1
		3/8-16	100	2.8
	<i>Available in zinc and stainless.</i>			

## RECOMMENDED BUCKET INSTALLATION

A locking device should be used on all elevator bucket installations.

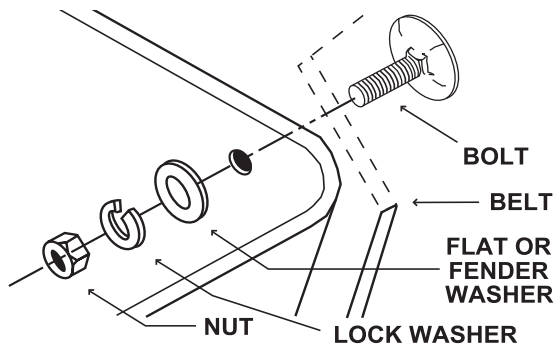

## DIRECTIONS FOR PROPER ELEVATOR BOLT TORQUE ON BELT

1. To tighten the nuts, use a torque wrench that will "click" out when proper setting is reached.
2. Run the elevator with the buckets empty for 4 hours.
3. Check all bolts to insure that the proper torque is maintained.

## WASHERS AND SPACERS

FLAT		SIZE, INCHES (ID)	PKG. QTY., PCS.	PKG. WEIGHT, LBS.	O.D. INCHES
		1/4	100	1.3	1
		5/16	100	2.0	7/8
		3/8	100	3.0	1
	<i>Available in zinc and stainless.</i>	1/2	100	3.8	1-3/8

SPLIT RING LOCK		SIZE, INCHES (ID)	PKG. QTY., PCS.	PKG. WEIGHT, LBS.	O.D. INCHES
		1/4	100	0.2	1-1/4
		5/16	100	0.4	7/8
		3/8	100	0.6	1
	<i>Available in zinc and stainless.</i>	1/2	100	1.4	1-3/8

FENDER*		SIZE, INCHES (ID)	PKG. QTY., PCS.	PKG. WEIGHT, LBS.	O.D. INCHES
		1/4	100	1.3	1
		Large 1/4	100	1.3	1-1/4
		5/16	100	2.0	1-1/4
		Large 5/16	100	3.0	1-1/2
		3/8	100	3.0	1
		1/2	100	3.8	1-3/8
	<i>Available in zinc and stainless.</i>				

\*When installing urethane buckets always use Fender Washers.

  

LEATHER		SIZE, INCHES (ID)	PKG. QTY., PCS.	PKG. WEIGHT, LBS.	O.D. INCHES
		1/4	100	0.3	1
		5/16	100	0.3	1
		3/8	100	0.3	1

POLY SPACERS		SIZE, INCHES (ID)	PKG. QTY., PCS.	PKG. WEIGHT, LBS.	O.D. INCHES
		1/4	100	2.0	-
		5/16	100	1.8	-
	<i>Available in 1/4" and 1/2" thick.</i>				

NEOPRENE		SIZE, INCHES (ID)	PKG. QTY., PCS.	PKG. WEIGHT, LBS.	O.D. INCHES
		1/4	100	1.1	-
		5/16	100	1.1	-
		3/8	100	1.1	-
	<i>Available in 1/4" thick.</i>				

RECOMMENDED TORQUE FOR ELEVATOR BOLTS						
SHANK DIAMETER	STEEL			STAINLESS		
	IN./LBS.	KGM/M.	FT./LBS.	IN./LBS.	KGM/M.	FT./LBS.
1/4"	50	0.57	4	86	.99	7.16
5/16"	96	1.10	8	177	2.04	14.75
3/8"	180	2.07	15	-	-	-